

# Rosa

**FASTENED STONE ACCENT SYSTEM**

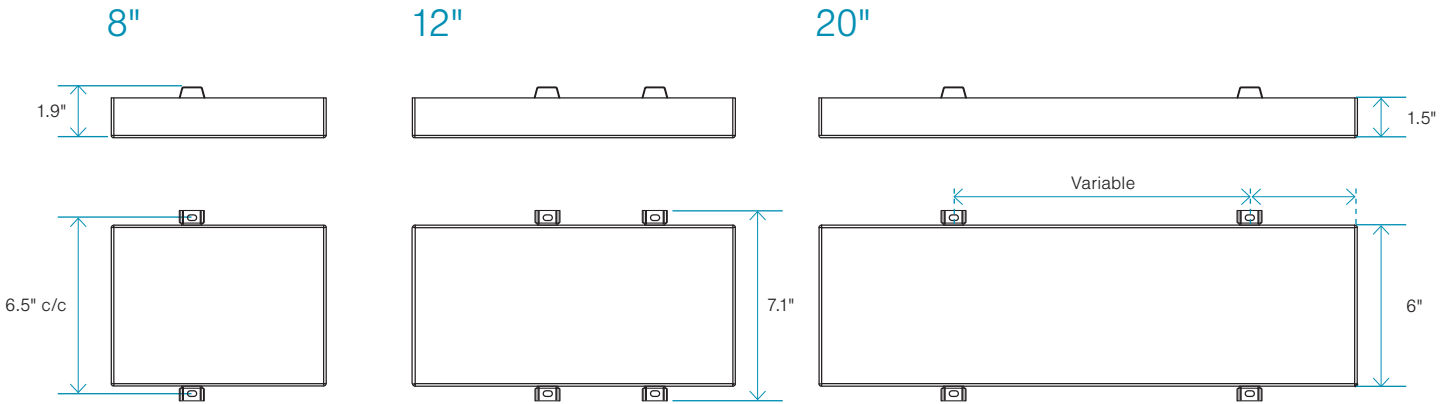

NOMINAL WIDTH	HEIGHT	DEPTH	FASTENING SYSTEM	OVERALL DIMENSIONS
8"	6"	1.5"	Screw-in	8" x 7.1" x 1.9"
12"	6"	1.5"	Screw-in	12" x 7.1" x 1.9"
20"	6"	1.5"	Screw-in	20" x 7.1" x 1.9"

## General Specifications

**SUBSTRATE**

- Cement and 35% recycled post-consumer glass composite.

**PACKAGING**

- 30 sq. ft. crates of stones.

**WEIGHT OF A CRATE**

- 450 lbs.

**AVAILABLE COLORS**

- Moorecrest;
- Almond.

Colors juxtaposed on a textured cement base to achieve that sought-after natural stone look. Rich variations that give each project its own unique personality.

**WARRANTY**

- 25 years

**TECHNICAL SPECS**

- Each crate contains:
  - Ratio of 2 x 20" stones to 1 x 8" stone and 1 x 12" stone;
  - 32 different surface patterns to ensure variability in final result;
  - Approximately 18 identified corner stones.

For exterior and interior use.